

X-Series ADAPT-a-SWITCH CARRIER MODULE

MODEL 1260-100X

PUBLICATION NO. 980914-100X

RACAL INSTRUMENTS

United States

(Corporate Headquarters and Service Center)
4 Goodyear Street, Irvine, CA 92618
Tel: (800) 722-2528, (949) 859-8999; Fax: (949) 859-7139

5730 Northwest Parkway Suite 700, San Antonio, TX 78249
Tel: (210) 699-6799; Fax: (210) 699-8857

Europe

(European Headquarters and Service Center)
18 Avenue Dutartre, 78150 LeChesnay, France
Tel: +33 (0)1 39 23 22 22; Fax: +33 (0)1 39 23 22 25

29-31 Cobham Road, Wimborne, Dorset BH21 7PF, United Kingdom
Tel: +44 (0) 1202 872800; Fax: +44 (0) 1202 870810

Via Milazzo 25, 20092 Cinisello B, Milan, Italy
Tel: +39 (0)2 6123 901; Fax: +39 (0)2 6129 3606

Racal Instruments Group Limited, Technologie Park, D-51429 Bergisch Gladbach, Germany
Tel: +49 2204 844205; Fax: +49 2204 844219

info@racalinstruments.com
sales@racalinstruments.com
helpdesk@racalinstruments.com
<http://www.racalinstruments.com>
info@racalinstruments.de
www.racalinstruments.de



PUBLICATION DATE: November 23, 2005

Copyright 2005 by Racal Instruments, Inc. Printed in the United States of America. All rights reserved.
This book or parts thereof may not be reproduced in any form without written permission of the publisher.

THANK YOU FOR PURCHASING THIS RACAL INSTRUMENTS PRODUCT.

For this product, or any other Racal Instruments product that incorporates software drivers, you may access our web site to verify and/or download the latest driver versions. The web address for driver downloads is:

<http://www.racalinstruments.com/downloads>

If you have any questions about software driver downloads or our privacy policy, please contact us at

info@racalinstruments.com

WARRANTY STATEMENT

All Racal Instruments, Inc. products are designed and manufactured to exacting standards and in full conformance to Racal's ISO 9001:2000 processes.

This warranty does not apply to defects resulting from any modification(s) of any product or part without Racal Instruments express written consent, or misuse of any product or part. The warranty also does not apply to fuses, software, non-rechargeable batteries, damage from battery leakage, or problems arising from normal wear, such as mechanical relay life, or failure to follow instructions.

This warranty is in lieu of all other warranties, expressed or implied, including any implied warranty of merchantability or fitness for a particular use. The remedies provided herein are buyer's sole and exclusive remedies.

For the specific terms of your standard warranty, or optional extended warranty or service agreement, contact your Racal customer service advisor. Please have the following information available to facilitate service.

1. Product serial number
2. Product model number
3. Your company and contact information

You may contact your customer service advisor by:

E-Mail:	Helpdesk@racalinstruments.com	
Telephone:	+1 800 722 3262	(USA)
	+44(0) 8706 080134	(UK)
Fax:	+1 949 859 7309	(USA)
	+44(0) 1628 662017	(UK)

RETURN of PRODUCT

Authorization is required from Racal Instruments before you send us your product for service or calibration. Call your nearest Racal Instruments support facility. A list is located on the last page of this manual. If you are unsure where to call, contact Racal Instruments, Inc. Customer Support Department in Irvine, California, USA at 1-800-722-3262 or 1-949-859-8999 or via fax at 1-949-859-7139. We can be reached at: helpdesk@racalstruments.com.

PROPRIETARY NOTICE

This document and the technical data herein disclosed, are proprietary to Racal Instruments, and shall not, without express written permission of Racal Instruments, be used, in whole or in part to solicit quotations from a competitive source or used for manufacture by anyone other than Racal Instruments. The information herein has been developed at private expense, and may only be used for operation and maintenance reference purposes or for purposes of engineering evaluation and incorporation into technical specifications and other documents which specify procurement of products from Racal Instruments.

DISCLAIMER

Buyer acknowledges and agrees that it is responsible for the operation of the goods purchased and should ensure that they are used properly and in accordance with this handbook and any other instructions provided by Seller. Racal Instruments products are not specifically designed, manufactured or intended to be used as parts, assemblies or components in planning, construction, maintenance or operation of a nuclear facility, or in life support or safety critical applications in which the failure of the Racal Instruments product could create a situation where personal injury or death could occur. Should Buyer purchase Racal Instruments product for such unintended application, Buyer shall indemnify and hold Racal Instruments, its officers, employees, subsidiaries, affiliates and distributors harmless against all claims arising out of a claim for personal injury or death associated with such unintended use.

FOR YOUR SAFETY

Before undertaking any troubleshooting, maintenance or exploratory procedure, read carefully the **WARNINGS** and **CAUTION** notices.



CAUTION
RISK OF ELECTRICAL SHOCK
DO NOT OPEN



This equipment contains voltage hazardous to human life and safety, and is capable of inflicting personal injury.



If this instrument is to be powered from the AC line (mains) through an auto-transformer, ensure the common connector is connected to the neutral (earth pole) of the power supply.



Before operating the unit, ensure the conductor (green wire) is connected to the ground (earth) conductor of the power outlet. Do not use a two-conductor extension cord or a three-prong/two-prong adapter. This will defeat the protective feature of the third conductor in the power cord.



Maintenance and calibration procedures sometimes call for operation of the unit with power applied and protective covers removed. Read the procedures and heed warnings to avoid “live” circuit points.

Before operating this instrument:

1. Ensure the proper fuse is in place for the power source to operate.
2. Ensure all other devices connected to or in proximity to this instrument are properly grounded or connected to the protective third-wire earth ground.

If the instrument:

- fails to operate satisfactorily
- shows visible damage
- has been stored under unfavorable conditions
- has sustained stress

Do not operate until, performance is checked by qualified personnel.

Table of Contents

Chapter 11-1

OVERVIEW.....1-1

 Items Shipped with 1260-100X.....1-1

 Part Numbers, Options and Ordering Information.....1-1

 Functional Description.....1-2

 Features1-3

 Compatibility with Racal Instruments 1260-Series1-3

 Ease of Use1-4

 Maintainability.....1-4

 Dynamically-Configured Analog Bus1-5

Chapter 22-1

GETTING STARTED2-1

 Unpacking and Inspection2-1

 Reshipment Instructions.....2-1

 Option-01T2-2

 Setting Configuration Switches2-4

 Local Bus Daisy-Chain Switches2-5

 Module Address Switch.....2-5

 Inserting and Removing Plug-Ins2-6

 Installing the 1260-100X into a VXIbus Chassis2-6

 Making Connections to Plug-Ins (Pin-Outs)2-7

 Power-On Self-Test.....2-7

 Closing and Opening Relays.....2-8

Chapter 3	3-1
USING THE 1260-100X.....	3-1
Checking the Response of Plug-Ins.....	3-1
Closing and Opening Relays.....	3-1
Emergency Reset Function.....	3-2
Description.....	3-2
Interface.....	3-2
Normal State of External Switch.....	3-2
Scope of Reset Event.....	3-3
Sequence of Events.....	3-3
Chapter 4	4-1
MAINTENANCE.....	4-1
Performance Verification Procedure.....	4-1
Purpose.....	4-1
Equipment Required.....	4-1
Software Required.....	4-2
Procedure.....	4-2
Chapter 5	5-1
PRODUCT SUPPORT.....	5-1
Product Support.....	5-1
Warranty.....	5-1
Support Offices.....	5-2

Appendix A.....	A-1
1260-100X SPECIFICATIONS.....	A-1
General.....	A-1
Mechanical	A-1
Electrical	A-1
Power and Cooling	A-2
Environmental.....	A-2
EMC and Safety.....	A-2
Reliability	A-2
 Appendix B.....	 B-1
1260-100X THEORY OF OPERATION	B-1
General.....	B-1
VXI Interface PCB Subassembly.....	B-1
Power Filtering.....	B-1
Signal Connections.....	B-2
OPTION-01T/Passport PCB Subassembly	B-2
Backplane/ Mezzanine PCB Subassembly	B-2
Local Bus Signal Routing	B-3
Reset Circuit	B-3
Interrupt	B-3
Communications	B-4
PLD Programming Connector.....	B-5

Appendix C C-1

TRUBLESHOOTING C-1

 Introduction..... C-1

 Troubleshooting Table..... C-1

 Communications Troubleshooting C-2

List of Figures

Figure 1-1, The 1260-100X Shown with Two X-series Adapt-a-Switch Cards Installed1-2

Figure 1-2, Ease-of-Use Features1-5

Figure 2-1, The Front View –Two Carriers Configuration.2-2

Figure 2-2, 1260-100X Configuration Switches2-4

Chapter 1

OVERVIEW

ITEMS SHIPPED WITH 1260-100X

The following items are shipped with each 1260-100X Adapt-a-Switch Carrier:

ITEM	RACAL PART NUMBER	QUANTITY
Retaining Plate, Top	457383-001	1
Retaining Plate, Middle	457383-003	1
Retaining Plate, Bottom	457383-002	1
Blanking plate	457403	1
Instruction manual	980914-100X	1

The following accessories may be ordered separately:

Blanking Plate	457403	1
EMI Shield	457376	1
Retaining Plate, Top	457383-001	1
Retaining Plate, Middle	457383-003	1
Retaining Plate, Bottom	457383-002	1

PART NUMBERS, OPTIONS AND ORDERING INFORMATION

The 1260-100X can be ordered as an assembly or as individual pieces as needed depending upon the application. The following Part Numbers are available as standard products:

408007

Includes: 408034 1260-100X Enclosure Assembly
4408035-100X Shipping Kit



Figure 1-1, The 1260-100X Shown with Two X-series Adapt-a-Switch Cards Installed

FUNCTIONAL DESCRIPTION

The 1260-100X Adapt-a-Switch Carrier (currently without Option 01T) is a two-slot VXI bus module that may contain up to six X-series Adapt-a-Switch plug-in cards. The X-series Adapt-a-Switch cards are 3.3" longer and 0.4" wider than the non X-series cards, thus allowing higher density relay configurations.

You may leave some slots unoccupied for future expansion.

Each plug-in has its own unique configuration of relays or digital testing capabilities, such as:

- Switch, for connecting individual pairs of inputs together.
- Multiplexer (MUX), for connecting one input to any one of several outputs.
- Matrix. A matrix has two groups of channels: a row and a column. The matrix can connect any row channel to any column channel. The matrix may make multiple independent connections at the same time.
- RF switch, for switching radio-frequency signals via impedance-matched signal paths.
- Digital I/O, for a wide range of digital test applications.

Features

Compatibility with Racal Instruments 1260- Series

Functionally, it is identical to the 1260-100 but currently without an Option-01T. It only accepts the X-series Adapt-a-Switch plug-in cards. The 1260-100X Adapt-a-Switch Carrier is controlled by the same Option-01T controller installed in another carrier in the same group as conventional Racal Instruments 1260-Series switch modules. A single Option-01T Switch Controller Module may control up to twelve switch modules or plug-ins. This may include a combination of 1260-Series and Adapt-a-Switch plug-ins.

See **Chapter 2: Getting Started** for instructions on combining 1260-Series modules and Adapt-a-Switch plug-ins in the same VXIbus chassis.

Ease of Use

The 1260-100X includes several ease-of-use features (the 1260-100X model is shown in Figure 1-2):

- Plug-ins are easy to insert and extract from the front panel of the 1260-100X, even while it is installed in a chassis.
- For only the 1260-100X, module addresses, used to uniquely identify each plug-in, are set by a single DIP switch that is easily accessible from the back of the 1260-100X. See **Setting Configuration Switches** in **Chapter 2: Getting Started** for instructions.
- The 1260-100X ejector handles also function as injectors, making it easy to install the carrier into a VXIbus chassis.

Maintainability

Maintainability of the 1260-100X is enhanced by the fact that plug-ins are removable from the front panel. This has the following benefits:

- The mean time to repair (MTTR) is minimized, since the carrier does not need to be disassembled or even removed from the VXIbus chassis.
- The switch system may be easily upgraded in the field by adding or changing plug-ins.
- Sparing is less costly and more flexible, since individual plug-ins may be spared rather than the entire 1260-100X module.

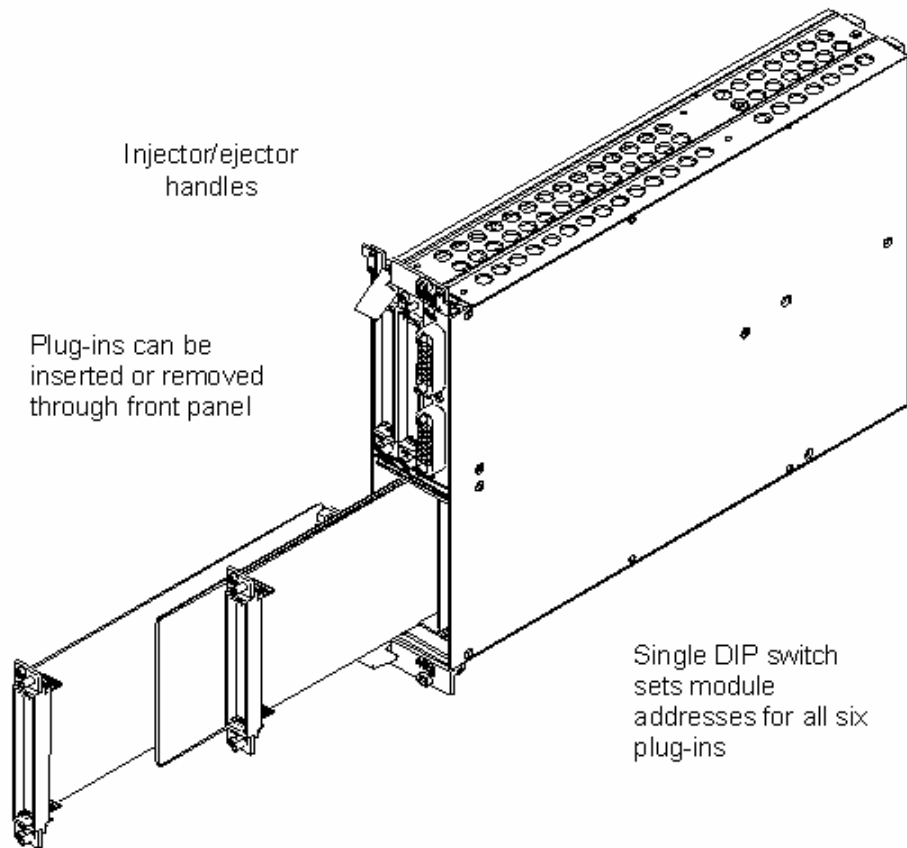

Figure 1-2, Ease-of-Use Features

Dynamically-Configured Analog Bus

The 1260-100X Adapt-a-Switch Carrier offers an analog bus to interconnect two or more plug-ins. This allows the creation of large multiplexers and matrices. The analog bus may be dynamically configured under software control.

For instructions in using the analog bus, refer to the instruction manuals for the individual multiplexer and matrix plug-ins.

This page was left intentionally blank.

Chapter 2

GETTING STARTED

Unpacking and Inspection



1. Before unpacking the switching module, check the exterior of the shipping carton for any signs of damage. All irregularities should be noted on the shipping bill and reported.
2. Remove the instrument from its carton, preserving the factory packaging as much as possible.
3. Inspect the switching module for any defects or damage. Immediately notify the carrier if any damage is apparent.
4. Have a qualified person check the instrument for safety before use.

Reshipment Instructions

1. Use the original packing material when returning the switching module to Racal Instruments for servicing. The original shipping carton and the instrument's plastic foam will provide the necessary support for safe reshipment.
2. If the original packing material is unavailable, wrap the switching module in an ESD Shielding bag and use plastic spray foam to surround and protect the instrument.
3. Reship in either the original or a new shipping carton.

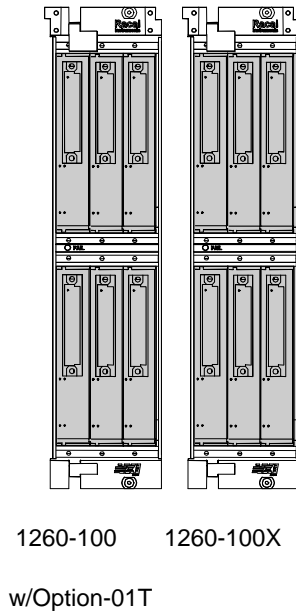

Figure 2-1, The Front View –Two Carriers Configuration.

Option-01T

Presently, the 1260-100X can be used only as a compatible 1260-type carrier adjacent to a 1260-100 module with an Option 01-T card installed, or as one of the several 1260-Series modules in consecutive slots.

The following rules apply when using the Option-01T controller:

1. Each Adapt-a-Switch or full-size VXI switch module has its own unique module address.
2. Model 1260-100 assigns module addresses 1 through 12, to its module slot, depending on the position of the Address Range DIP switch.
3. To be controlled by a single Option-01T, a group of switch modules and carriers must be installed in a contiguous group of VXIbus chassis slots and the Option-01T must be installed in the left-most module in the group.

Below are some examples of possible configurations:

Example 1:

A single Option-01T may control all Adapt-a-Switch plug-ins in one or two 1260-100X Carriers. When it controls two carriers, the carriers must be in adjacent slots in the VXIbus chassis, with the Option-01T-equipped carrier in the left-most slot of the group.

A single Option-01T may control all Adapt-a-Switch plug-ins in a 1260-101, a 1260-100, or a 1260-100X Carriers. When it controls two carriers, the carriers must be in adjacent slots in the VXIbus chassis, with the Option-01T-equipped carrier in the left-most slot of the group. A single option_01T will not control more than one 1260-101.

Example 2:

A single Option-01T may control a group of 1260-Series switch modules. The modules must be installed in a contiguous group of slots in the VXIbus chassis. Figure 2-1 shows the configuration which the left most 1260-100 carrier is with Option 01-T installed and one 1260-100X carrier.

Example 3:

A single Option-01T may control a mixed group of 1260-Series switch modules and Adapt-a-Switch plug-ins. The maximum number of items in each group is twelve. Each 1260-100X carrier counts as six plug-ins and each 1260-101 carrier counts as two plug-ins, regardless of the quantity of plug-ins actually installed. For instance, a single Option-01T may control the following group:

- Slot 3:1260-54 RF Switch (conventional one-slot VXI module), equipped with Option-01T
- Slots 4 and 5:1260-100 Adapt-a-Switch carrier, containing three 1260-138 plug-ins and two 1260-150 RF switch plug-ins.
- Slot 6:1260-22 Power Switch (conventional one-slot VXI module)
- Slot 7:1260-22 Power Switch

- Slot 8: 1260-101 Adapt-a-Switch carrier, containing one 1260-145.

The above group counts as eleven items: the 1260-54 and 1260-22 modules count as one item each, for a total of three. The 1260-100X carrier is considered as six items, regardless of the number of plug-ins installed. The 1260-101 carrier is considered as two items. Adding these together, the total number of controlled items is eleven. This means that there is still room to add one 1260-Series switch modules to the group, with the entire group controlled by one Option-01T. The Option-01T must be installed in the 1260-54 module in slot 3. In the case where an Option-01T controls plug-ins residing in two adjacent carriers, the Option-01T must be installed in the carrier on the left.

For groups that are larger than twelve, additional Option-01T modules are used.

Setting Configuration Switches

Model 1260-100X has its own configuration switches located on the back panel (See **Figure 2-2**).

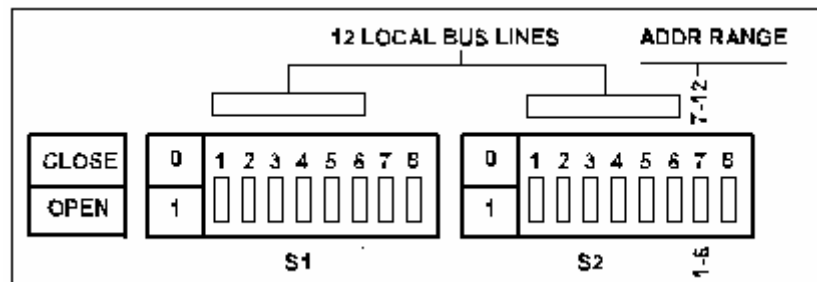

Figure 2-2, 1260-100X Configuration Switches

Set these switches as follows:

Local Bus Daisy-Chain Switches

Currently, the 1260-100X requires another carrier with an Option-01T installed in the adjacent left slot.

If you are using a 1260-100X Carrier as the last carrier in the VXI chassis with no switch modules or carriers to its right, set all twelve local bus daisy-chain switches to the OPEN position. On the other hand, if you install a 1260-Series switch module or another 1260-100X Carrier to the immediate right, set all twelve local bus daisy-chain switches (S1 positions 1-6 and S2 positions 1-6) to the CLOSE position. This allows the Option-01T in the carrier of the adjacent left slot to control not only the plug-ins in that carrier, but the switch modules installed to the right, as well.

Module Address Switch

Although plug-ins and 1260-Series modules do not require logical addresses (the Option-01T has one instead), they each have a *module address*. The Option-01T uses module addresses to distinguish between plug-ins, and between 1260-Series modules.

Each plug-in or module must have a unique module address from one through twelve, inclusive. Models 1260-100X assigns module addresses as follows:

1260-100X Module Address

The module address DIP switch S2 position 7 (see figure 2-2) sets the logical addresses for all plug-ins in the 1260-100X Carrier. The switch has two settings:

- 1-6 (opened) When the switch is set to this position, the module addresses of the plug-ins are from 1 through 6, with 1 being in the left slot of the top row. The plug-ins are addressed in the following pattern:
- 7-12 (closed) When the switch is set to this position, the module addresses of the plug-ins are from 7 through 12, in the following pattern:

Inserting and Removing Plug-Ins

CAUTION

If the 1260-100X Carrier is in a VXIbus chassis, make sure the chassis power is off before inserting or removing plug-ins.

Use proper anti-static handling procedures when plug-ins are outside the carrier.

Figure 1-2 shows how to insert or remove a plug-in. Prior to inserting or removing a plug-in, the retaining plates have to be removed. For examples, to insert or remove a plug-in in slots 1, 2, or 3, the top and middle retaining plates have to be removed. To insert a plug-in in slots 4, 5, and 6, the middle and bottom retaining plates have to be removed. To insert a plug-in, position the module so that the edges align with the grooves in the carrier slot. Slide the plug-in all the way into the carrier, then press firmly to engage its connector with the carrier backplane. Replace the plug-in retaining plates and tighten the screws securely.

To remove a plug-in, remove the retaining plates as stated previously to make them float freely. Since they are captive, they do not come completely out. Pull firmly and evenly on the front panel to disengage the plug-in from the backplane, then pull the plug-in out of the carrier.

INSTALLING THE 1260-100X INTO A VXIBUS CHASSIS

To install the 1260-100X Carrier into a VXIbus chassis, position the carrier so that the ridges at the top and bottom align with the grooves in the chassis slots (see Figure 1-3). As you push the carrier into the chassis, ensure that the injector/ejector handles are in the proper positions. The upper handle should be all the way up, and the lower handle should be all the way down. Push the carrier into the chassis until it stops. Then use the injector/ejector handles to engage the carrier with the chassis backplane. Simultaneously push the upper handle downward and the lower handle upward until the carrier is fully inserted. Tighten the upper and lower retaining screws.

To remove the 1260-100X Carrier from the VXIbus chassis, loosen the upper and lower retaining screws. Simultaneously push the upper injector handle upward and pull the lower handle downward until the carrier is disengaged from the chassis backplane. Then slide the carrier out of the chassis.

Making Connections to Plug-Ins (Pin- Outs)

For information about connecting external equipment to the plug-ins, refer to the individual manuals for the plug-ins. These include information regarding mating connector part numbers, pin-outs, and electrical ratings.

Power-On Self- Test

When the VXIbus chassis is switched on, the Option-01T in the system automatically runs a self-test and the Fail LED in a carrier with an Option-01T will illuminate.

When the Option-01T in the system completes self-test, the Fail LED will extinguish. This occurs within five seconds after chassis power is turned on.

The self-test includes the following:

1. PROM checksum
2. RAM write/read pattern verification
3. Microprocessor instruction test
4. Non-volatile RAM verification
5. Timer test

This self-test represents 70% fault detection.

Closing and Opening Relays

For general commands to close and open relays, refer to the section **Closing a Relay** in **Chapter 1: Getting Started** of the Option-01T Instruction Manual. Other commands are specific to individual plug-ins. For detailed information on module-specific commands, refer to the instruction manual for the appropriate plug-in.

Chapter 3

USING THE 1260-100X

Checking the Response of Plug-Ins

To verify that the plug-ins are operational, send the `MOD:LIST?` command to the Option-01T. Then read back the response of the Option-01T. The Option-01T responds with a message specifying which plug-ins and 1260-Series modules are under its control. If the Option-01T does not respond, or does not properly list the installed switch products, refer to **Appendix C: Troubleshooting**.

Closing and Opening Relays

To use the message-based mode of communication, refer to Chapter 2 of the Option-01T Instruction Manual for general commands. For module-specific commands, refer to the individual manuals for the plug-ins.

For high-speed operation, use the register-based mode with Racal Instruments *VXIplug&play* drivers. For detailed information, refer to the **VISA and the VXIplug&play Software** section of **Chapter 2: Using the Option-01T** in the Option-01T Instruction Manual.

Emergency Reset Function

Description

To enhance safety in applications that involve power switching, certain Adapt-a-Switch plug-ins and conventional 1260-Series modules offer an emergency reset function, activated by an external input. This function instantly opens all relays in response to an external event. This is a hardware operation that does not require intervention on the part of the Option-01T or application software.

When using the emergency reset feature, exercise due caution if any undesirable effects may result from opening all channels.

Interface

Select Adapt-a-Switch plug-ins and 1260-Series modules have a pair of front-panel-mounted connector pins. You may connect these to an external device such as a mechanical switch. When the switch is opened, all relays on the plug-in or module are immediately opened.

An example of a plug-in that provides the emergency switch interface is the 1260-120 Power Switch. All other plug-ins and 1260-Series modules that provide the switch interface operate in the same manner as the 1260-120.

Normal State of External Switch

If desired, a jumper setting on the plug-ins allows it to accommodate a normally-closed external switch. Normally-open is the default. Refer to the individual plug-in manual.

Scope of Reset Event

The 1260-120 design allows the scope of an emergency reset to be configured. In the default configuration, the 1260-120 opens only its own relays in response to an external reset event. If desired, a jumper setting on the 1260-120 may be changed so that the effect of an emergency reset is global. With the global reset configuration, a reset signal propagates through the VXI Local Bus to open all relays on all switch products that are connected to the same Option-01T.

All Racal 1260-Series and Adapt-a-Switch plug-ins respond to an emergency reset condition when the scope is set to global. Certain plug-ins and 1260-Series modules provide the front-panel contacts for the external switch, and the circuitry to recognize a reset event. A switch system may make full use of the emergency reset feature if it includes at least one plug-in or 1260-Series module that has reset recognition capability.

Sequence of Events

When a reset event occurs, the following sequence takes place:

1. The plug-in that is connected to the external switch recognizes the reset event and sets a logic latch.
2. All relays are opened on the switch product that recognized the reset event. If the scope of the reset function is set to global, then all relays on all switch products connected to the same Option-01T are also opened. This happens independently of software.
3. An interrupt is generated to notify the Option-01T that a reset event has occurred. This informs the Option-01T that the relays have opened, so that it remains up-to-date on the relay status.
4. The relays remain open and do not respond to any commands from the Option-01T.
5. After the reset condition is removed (the external switch is returned to its normal position), the relays remain open until otherwise commanded by the Option-01T.

Other Adapt-a-Switch plug-ins and 1260-Series modules that are equipped to recognize an emergency reset are configured and operate the same way as the 1260-120. It is important to note that a global reset condition opens relays on all plug-ins and 1260-Series modules that are connected to the same Option-01T, regardless of whether they are equipped with the interface for the external reset switch.

This page was left intentionally blank.

Chapter 4

MAINTENANCE

Performance Verification Procedure

Purpose

The following procedure verifies the basic functions of the 1260-100X Adapt-a-Switch Carrier. Test coverage includes:

- Option-01T power-on self-test
- Option-01T basic operation in message based mode
- Option-01T operation in register-based mode
- 1260-100X receive and transmit functions.

Equipment Required

- VXIbus chassis
- Embedded slot 0 controller, or MXI slot 0 controller with IBM-compatible PC
- A carrier with an Option-01T installed.

Software Required

- Microsoft Windows 95, 98, ME, NT, 2000, and XP
- VXI Resource Manager (RESMAN) by National Instruments
- VXI Interactive Control (VIC) by National Instruments

Procedure

1. Ensure that an Option-01T is installed in the carrier adjacent to the 1260-100X carrier as outlined in the **Option-01T** section of **Chapter 2: Getting Started**.
2. Set the Option-01T logical address switch to 3.
3. Set the **1260-100X** module address switch to the 1-6 position.
4. Install the carrier into an empty pair of slots in a VXIbus chassis. Remove all other modules from the chassis except the slot 0 controller and the carrier with an Option-01T.
5. Insert one or more plug-ins into the 1260-100X Carrier.
6. Turn the chassis power on. Verify that the Fail LED on the carrier with an Option 01T illuminates, then extinguishes within five seconds.
7. Run the National Instruments Resource Manager program (RESMAN). From the RESMAN output log file, verify the following:
8. The Option-01T is recognized as DEVICE_3.
9. The self-test for DEVICE_3 passed.
10. 16K-bytes of memory are allocated for DEVICE_3.
11. Start the VXI Interactive Control (VIC) program (by National Instruments).

12. Send a *IDN? command to DEVICE_3 (Option-01T).
13. Read the response from the Option-01T. Verify that the response is of the form:
14. Racal Instruments,1260A Option-01T,<serial num>,<revision>
15. where <serial num> is the serial number, and <revision> is the revision level of the firmware.
16. Click on the Bus Access feature of VIC. Select the WRITE mode.
17. Calculate the address offset of one of the Adapta-Switch plug-ins. To do this, begin with the address reported by RESMAN as being the starting address for DEVICE_3. Add 1. Then add 400_{16} times the module address of the plug-in. Enter this address into the ADDRESS field in VIC.
18. Select the A24 address mode.
19. In the data field, enter 55_{16} . Click on GO. If the plug-in is a relay type (not a digital type), you should hear the relays close.
20. Select the READ mode, set the number of bytes to at least 1, and click on GO. Verify that the Option-01T responds with AA_{16} , which is the one's compliment of the data written.
21. In the data field, enter AA_{16} . Click on GO. If the plug-in is a relay type (not a digital type), you should hear the relays open.
22. Select the READ mode, set the number of bytes to at least 1, and click on GO. Verify that the Option-01T responds with 55_{16} , which is the one's compliment of the data written.
23. Repeat steps 12 through 17 for each of the remaining plug-ins.
24. Turn the chassis power switch off.
25. If fewer plug-ins are available than the number of

slots, repeat steps 5 through 18 with the plug-ins in different slots until all carrier slots have been tested.

26. For the 1260-100X set the module address switch on the carrier to the 7-12 position. Repeat steps 5 through 20. When calculating the address offset in step 12, remember that the module addresses now range from 7 through 12.

Chapter 5

PRODUCT SUPPORT

PRODUCT SUPPORT

Racal Instruments has a complete Service and Parts Department. If you need technical assistance or should it be necessary to return your product for repair or calibration, call 1-800-722-3262. If parts are required to repair the product at your facility, call 1-949-859-8999 and ask for the Parts Department.

When sending your instrument in for repair, complete the form in the back of this manual.

For worldwide support and the office closes to your facility, refer to the Support Offices section on the following page.

WARRANTY

Use the original packing material when returning the 1260-100X to Racal Instruments for calibration or servicing. The original shipping container and associated packaging material will provide the necessary protection for safe reshipment.

If the original packing material is unavailable, contact Racal Instruments Customer Service for information.

SUPPORT OFFICES

RACAL INSTRUMENTS

United States

(Corporate Headquarters and Service Center)
4 Goodyear Street, Irvine, CA 92618
Tel: (800) 722-2528, (949) 859-8999; Fax: (949) 859-7139

5730 Northwest Parkway Suite 700, San Antonio, TX 78249
Tel: (210) 699-6799; Fax: (210) 699-8857

Europe

(European Headquarters and Service Center)
18 Avenue Dutartre, 78150 LeChesnay, France
Tel: +33 (0)1 39 23 22 22; Fax: +33 (0)1 39 23 22 25

29-31 Cobham Road, Wimborne, Dorset BH21 7PF, United Kingdom
Tel: +44 (0) 1202 872800; Fax: +44 (0) 1202 870810

Via Milazzo 25, 20092 Cinisello B, Milan, Italy
Tel: +39 (0)2 6123 901; Fax: +39 (0)2 6129 3606

Racal Instruments Group Limited, Technologie Park,
D-51429 Bergisch Gladbach, Germany
Tel: +49 2204 844205; Fax: +49 2204 844219

Repair and Calibration Request Form

To allow us to better understand your repair requests, we suggest you use the following outline when calling and include a copy with your instrument to be sent to the Racal Repair Facility.

Model _____ Serial No. _____ Date _____

Company Name _____ Purchase Order # _____

Billing Address _____

City

State/Province

Zip/Postal Code

Country

Shipping Address _____

City

State/Province

Zip/Postal Code

Country

Technical Contact _____ Phone Number () _____

Purchasing Contact _____ Phone Number () _____

1. Describe, in detail, the problem and symptoms you are having. Please include all set up details, such as input/output levels, frequencies, waveform details, etc.

2. If problem is occurring when unit is in remote, please list the program strings used and the controller type.

3. Please give any additional information you feel would be beneficial in facilitating a faster repair time (i.e., modifications, etc.)

4. Is calibration data required? Yes No (please circle one)

Call before shipping
Note: We do not accept
"collect" shipments.

Ship instruments to nearest support office.

This page was left intentionally blank.

Appendix A

1260-100X SPECIFICATIONS

GENERAL

1260 Series Compatibility	Needs to be controlled by an Option 01T installed in another carrier
Annunciators	NONE
Host Interface	VXIbus backplane
Control Type	Message-based. Register based: VXIbus A24 address space.
Switching Response Time*	
Register-based:	9 μ s max.
Message-based:	10 ms typ.
VXI Plug&Play	Compatible drivers for all 1260-Series switching modules

Mechanical

Size	VXIbus C-size, two-slot module
Module Capacity	Six Adapt-a-Switch plug-ins
Weight (empty carrier)	Weight: 4.3 lbs (2.0 kg)
Front-Panel Connectors	Provided by each plug-in switch card

Electrical

Indicators	NONE
RF Shielding	Fixed steel shields between plug-in slots
Analog Bus	Four two-wire channels 50-ohm impedance differential Pair 2A current capacity

Power and Cooling

Power Consumption (without plug-ins)	+5V: 1.0A +12V: 0A +24V: 0A
Power Available (per plug-in)	+5V: 2.5A +12V: 1.0A +24V: 1.0A
Cooling (worst-case plug-in configuration)	Airflow: 3.0 liters/sec Backpressure: 0.7 mm H ₂ O

Environmental

Temperature	Operating: 0°C to +55°C Non-operating: -40°C to +70°C
Relative Humidity	95% RH non-condensing
Altitude	Operating: 10,000 ft. Non-operating: 15,000 ft.
Vibration	0.013 in. P-P, 5 Hz to 55 Hz; meets MIL-T-28800C Type III, Class 5, Style F
Shock	30g, 11 ms, 1/2 sine wave
Bench Handling	4 inch drop at 45°

EMC and Safety

Emissions	EN61326: 1997+A1:1998, Class A
Susceptibility, Safety	EN61010-1:1993+A2:1995

Reliability

Mean Time Between Failures (MTBF)	646,921 hours, MIL-HBK-217, ground-benign, 25°C
Mean Time To Repair (MTTR)	Replace plug-in: 5 min. Replace other: <30 min.

*Measured from start of VXIbus cycle until relay coil is fully energized.

Appendix B

1260-100X THEORY OF OPERATION

GENERAL

The 1260-100X consists of three PCB subassemblies: VXI Interface, Option 01T/Passport, and Backplane/Mezzanine PCB subassemblies.

VXI INTERFACE PCB SUB- ASSEMBLY

The VXI Interface PCB assembly serves two functions. It connects +5V, +12V, and +24V power from the VXIbus backplane to the 1260-100X backplane. It also connects the VXIbus backplane signals to the

Power Filtering

The power is filtered before reaching Option-01T/Passport subassembly. The fuses, F1 through F3, are of the surface-mount type. The fuses used are as follows.

FUSE	MANUFACTURER	MANUFACTURER'S PART NUMBER	RATING (AMPS)	RACAL PART NUMBER
F1	Wickmann USA, Inc.	418 2100000	10	921545
F2	Wickmann USA, Inc.	417 1315000	3.15	921546
F3	Wickmann USA, Inc.	417 1315000	3.15	921546

Signal Connections

Connectors P1, P2, P3, and P4 connect to the VXIbus backplane. Connectors J8 and J9 pass the VXI bus signals and +5V, +12V and +24V to the Option-01T/Passport PCB subassembly.

DIP switches S1 pins 1 through 6 and S2 pins 1 through 6 set the local bus pass through. S2 pin 7 sets the module address of the plug-ins. If S2 pin 7 is set to OFF position, the module addresses of the plug-ins are set to operation from 1 through 6. If S2 pin 7 is set to ON position, the module addresses of the plug-ins are set to operate from 7 through 12, which connects to the VXI backplane. The Bridge then connects to these signals using its P2 connector.

OPTION-01T/Passport PCB Sub-assembly

Currently Option-01T controller circuit is not available for 1260-100X carrier. So the 1260-100X is controlled by another carrier with Option-01T installed.

Without the Option-01T controller circuit, the Option-01T/Passport PCB subassembly only provides the pass through local bus signals, +5V, +12, +24V power and Ground signals to the Backplane/Mezzanine PCB subassembly.

Backplane/Mezzanine PCB Subassembly

Signals

The backplane/Mezzanine PCB subassembly provides bridging functions between the plug-ins and the Option-01T/Passport PCB subassembly. All communications signals are connected in parallel to all six plug-ins, except LBOARDSEL1 through LBOARDSEL6. These six signals route to their respective plug-in slots, and identify which plug-in is currently addressed.

The backplane also provides an analog bus. This bus consists of four pairs of PCB traces that daisy-chain from one plug-in to the next, connecting to all six slots in parallel. Each pair of traces is impedance-matched to 50 ohms, and is routed for maximum isolation and minimum crosstalk.

Local Bus Signal Routing

The Backplane/Mezzanine PCB subassembly provides the bridge circuitry to interface between the plug-ins and the Option-01T. It receives the local bus signals from the Option-01T on connector P2A.

The local bus signals LBUSC00S through LBUSC09S are differential. U4 and U5 converts LBUSC00S through LBUSC07S to TTL levels. LBUSC08S and LBUSC09S are a bidirectional differential pair. U5 and U8 receive and drive these signals, respectively.

Reset Circuit

U1 is a voltage monitor used to reset the Bridge and plug-ins at power turn-on. At power turn-on, it drives LLOGICRST low for approximately 130ms. It then takes LLOGICRST high and leaves it high, unless +5V power drops below 4.5V.

The signal LBUSC10S is an open-collector line from the Option-01T. During power turn-on, the Option-01T drives LBUSC10S low for about 100ms, then allows it to be pulled high. While LBUSC10S is low, it resets all relay drivers on all plug-ins to the inactive state, opening all relays. It also clears all outputs on digital test plug-ins to a known state.

LBUSC10S also serves another function when a plug-in asserts a global reset during an emergency reset event. When such an event occurs, the plug-in drives LBUSC10S low. It leaves it low until the event has passed and the Option-01T firmware clears the reset latch in the plug-in.

LBUSC10S also connects to all other devices controlled by the same Option-01T. When any device in this group asserts a global reset, all devices in the group respond by resetting their drivers.

Interrupt

The signal LBUSC11S is an open-collector line to the Option-01T. It has two purposes. When a plug-in asserts an emergency reset condition, it drives the LBUSC11S signal low. Also, the 1260-114 drives the LBUSC11S signal low to announce a synchronous event. When LBUSC11S goes low, the Option-01T polls the plug-ins to determine which one generated the interrupt. It then responds accordingly.

Communications

U3 is a programmable logic device (PLD) that handles the communications between the plug-ins and the Option-01T. It implements the same state machine used in 1260-Series switch modules. communications proceed as follows.

When the Option-01T is about to write data to a plug-in, it takes HLBUS_A/D to a logic 1, indicating that the data to be serially shifted out will be an address. It also drives the HLBUS_R/W signal low to indicate that data will be written. It then outputs an 8MHz clock on HLBUS_CLK, and places serial data on HLBUS_DATAIN, synchronous with HLBUS_CLK. The first 13 bits of data represent the address to be written to, with the most-significant bit first. This address is relative to the A24 address offset assigned to the Option-01T by RESMAN. For example, address 0 references the first address in the space allocated to the Option-01T.

The 13 address bits are clocked into a shift register internal to U3. The parallel outputs of this shift register are connected directly to all six plug-ins via the 1260-100 backplane.

After sending the address, The Option-01T drives HLBUS_A/D low, indicating that the next data sent will be data. It then shifts the serial data that will be written to the address just sent. There are eight data bits, with the most-significant bit sent first.

After the last data bit has been sent, the signal HLBUS_STROBE transitions to a logic high for one clock period of HLBUS_CLK. HLBUS_STROBE is sent to the six plug-ins. The plug-in containing the addressed device uses HLBUS_STROBE to latch the data into the device.

To read data from a plug-in, the Option-01T begins by taking HLBUS_A/D to a logic 1, indicating that the data to be serially shifted out will be an address. It also drives the HLBUS_R/W signal high to indicate that data will be read. It then outputs an 8.25 clock on HLBUS_CLK, and shifts the address out on HLBUS_DATAIN, as it does when writing.

The 13 address bits are clocked into U5 and U6, as when writing. After sending the address, the Option-01T drives the HLBUS_A/D low, indicating that it is ready for data. The plug-in containing the addressed device begins shifting serial data onto HLBUS_DATAOUT. There are eight data bits, with the most-significant bit sent first.

The signal HLBUS_STROBE is used only when writing, not when reading. During reading, it remains at logic 0.

PLD Programming Connector

J9 is a 10-pin header that is connected to the PLD (U3). It uses the JTAG interface to allow in-system programming of the PLD during upgrades or troubleshooting.

This page was left intentionally blank.

Appendix C

TROUBLESHOOTING

INTRODUCTION

If you have difficulty in using the 1260-100X Adapt-a-Switch Carrier or its plug-ins, refer to the following troubleshooting table. If you are still unable to resolve the problem, contact one of the Racal Customer Support offices listed in **Chapter 5: Support Offices**.

TROUBLESHOOTING TABLE

PROBLEM	POSSIBLE CAUSES	WHAT TO DO
No response from plug-in via VXIbus.	<ul style="list-style-type: none"> • Option-01T not installed in the carrier controlling the 1260-100X, or installed in incorrect module. • Module addresses conflicting. • Plug-in not fully seated. • Communication problem with Option-01T, 1260-100X Carrier, or plug-in. 	<ul style="list-style-type: none"> • Option-01T must be installed in left-most carrier or 1260-Series module in group. See Option-01T in Chapter 2: Getting Started. • Please note that currently 1260-100X does not have an Option-01T feature. It requires another carrier with an Option-01T to control it. • Ensure that each plug-in and 1260-Series module has its own unique module address. See Module Address Switch in Chapter 2: Getting Started. • Ensure that plug-in is firmly engaged. • See special troubleshooting procedure below, entitled "Communications Troubleshooting"

PROBLEM	POSSIBLE CAUSES	WHAT TO DO
Plug-in does not appear in <i>VXIplug&play</i> soft panel list.	<ul style="list-style-type: none"> Soft panel driver not installed. Communication problem with Option-01T, 1260-100X Carrier, or plug-in. 	<ul style="list-style-type: none"> Install 1260 Soft Front Panel Driver. See special troubleshooting procedure below, entitled "Communications Troubleshooting".
Switch modules to the right of the 1260-100X does not appear in <i>VXIplug&play</i> soft panel list (1260-100X plug-ins do appear).	<ul style="list-style-type: none"> Local Bus daisy-chain switches not closed. 	<ul style="list-style-type: none"> Close all twelve Local Bus daisy-chain switches on 1260-100X Carrier when another carrier or 1260-Series module is installed to its immediate right.
Relays do not close when commanded, but plug-in appears in <i>VXIplug&play</i> soft panel list.	<ul style="list-style-type: none"> Emergency reset function activated 	<ul style="list-style-type: none"> If external switch is connected, ensure that it is in the inactive position. See the Emergency Reset Function section in Chapter 3.

Communications Troubleshooting

Please note that temporarily 1260-100X does not have an Option-01T feature. It requires another module with an Option-01T to the left-most of the group.

Try the following procedure if you have trouble operating the plug-ins. If you still have difficulty, contact Racal Customer Support **Chapter 5: Product Support**.

1. Turn off the VXIbus chassis power switch. Wait at least two seconds, then turn it back on. The Fail LED on the left-most 1260-series Carrier with the controlling Option-01T. 1260-Series module should illuminate, then go out within five seconds. If it does, then proceed to step 2. If the Fail LED does not illuminate when power is turned on, then go to step 6. If the Fail LED illuminates, and stays on after five seconds, then the Option-01T may be defective; contact Racal Customer Support.

2. Send a *IDN? command to the Option-01T, then read the response. It should be in the following format:

```
Racal Instruments,1260A Option-01T,<serial num>,<revision>
```

where <serial num> is the serial number, and <revision> is the revision level of the firmware. If the Option-01T responds with a message in this form, then proceed to step 3. Otherwise, go to step 8.

3. Execute the Racal Instruments 1260-Series soft front panel program. It should display a list of all plug-ins and 1260-Series modules that are connected to the Option-01T. If it does not display a list, then go to step 8. Otherwise, proceed with step 4.
4. If the list displayed in step 3 is complete, then go to step 5. Otherwise, go to step 10.
5. Since the list of plug-ins is complete, the Option-01T is successfully communicating with all of the plug-ins. If you still have other communication difficulties, contact Racal Customer Support.
6. If this fails to correct the problem, then contact Racal Customer Support.
7. Try to isolate the problem to a single 1260-100X Carrier or 1260-Series module by removing others from the chassis. Remember the Option-01T is installed in the left-most module in the group.

For problems with Option-01T, please refer to the user manual of the controlling carrier with the Option-01T installed.